

# Design and Simulation of an Intelligent Traffic Light System for Cross Road at G.R.A Junction, Aba Road, Port Harcourt

Bodunrin I. Bakare<sup>1</sup>, Sunny Orike<sup>2</sup> and Tam E. Ikpuku<sup>1</sup>

<sup>1</sup>Department of Electrical Engineering, Rivers State University

<sup>2</sup>Department of Computer Engineering, Rivers State University

Nkpolu-Oroworukwo, Port-Harcourt

[bakare.bodunrin@ust.edu.ng](mailto:bakare.bodunrin@ust.edu.ng)

## ABSTRACT:

*This paper presents the design and simulation of an intelligent traffic light control system for Cross road at Government Reserved Area (GRA) junction along Aba Road, Port Harcourt in Rivers State. This was motivated on the need to reduce traffic congestion in GRA junction Port Harcourt during rush hours. The system was developed on the Arduino 1.8.7 integrated development environment (IDE), implemented using the C++ programming language and simulated on the Proteus 8.9 SP3 platform. The design was based on signal timing sequence and lane population detection. Two Light Dependent Resistors (LDR) sensors were assumed to be placed per lane and 32m apart from each other to accommodate 7 vehicles. The operation is based on signal timing sequence when all lanes have approximately the same population of vehicles and when the population on the number of vehicles on each lane does not exceed 7. Lane preference was activated by the lane population sensors when the population of vehicles in a lane exceeds or was at the second lane population detection (LDR) on that lane thus giving such lane or lanes right of way and ignoring the lane with less vehicles. The results show that when this sequence was in place, only one lane was passed (given the right of way) at a time thus ensuring safety of vehicles plying the road.*

**Keywords:** Arduino, Lane population detection, Programmable logic controller, Simulation, Traffic light control.

Cite This Article: Bakare, B. I., Orike, S. and Ikpuku, T. E. (2020). Design and Simulation of an Intelligent Traffic Light System for Cross Road at G.R.A Junction, Aba Road, Port Harcourt. Journal of Newviews in Engineering and Technology (JNET), 2 (3), 22-29

## 1.0 INTRODUCTION:

An intelligent traffic system refers to information and communication technology systems that control road traffic with the aid of programs embedded in microcontrollers/microprocessors in

order to facilitate the safety and comfort of road users.

Traffic lights, also known as traffic signals, traffic lamps, traffic semaphore, signal lights and traffic control signals are signaling systems that are placed at road intersections and other locations for the control of road traffic. The world's first traffic light although short lived, was installed in London in December of 1868. It was a gas operated system resulting in its explosion in less than a month after installation, injuring its policeman operator. Traffic control started to become necessary in the late 1890s with Earnest Serrine from Chicago patenting the first automated traffic control system in 1910. It employed the words "STOP" and "PROCEED", neither of which lit up (Scholz, 2008).

Over the years, lots of research had advanced the earlier design to the modern-day traffic light system that operates on signal timing control mechanism. Signal timing refers to the method employed by traffic engineers to allocate right-of-way at a signalized intersection. It deals with determining how much green time the traffic signal allocates to an intersection, time taken for the pedestrian WALK signal to be ON, and numerous other factors (Urbanik *et al.*, 2015).

Traffic congestion at the GRA Junction poses an ever-increasing problem across the city of Port Harcourt. As the population continues to grow in Port Harcourt and the number of licensed driver's increases, the problem will inevitably worsen. There are many causes of the traffic congestion at the GRA junction such as the massive increase in the numbers of vehicle, human habits, social behavior, and the traffic light system at that axis of Port Harcourt. These lights work based only

on signal timing ignoring the number of vehicles on each lane is ignored. Considering this, there is need for a traffic light system which actuation is dependent on the lane population density (Muzy *et al.*, 2015).

There are basically two categories of traffic light systems: pre-timed controlled and actuated control (Mahmood *et al.*, 2009). Pre-timed signals provide each intersection approach a fixed amount of time on a round robin basis, serving each approach consecutively, and repeating the pattern. In actuated control, the control of the traffic signal is dependent on mechanisms that detect vehicles approaching the intersection. Green time is allocated to where detection has occurred. Lanes where no detection is noticed are skipped. There are two types of actuated control: semi actuated control and fully actuated control (Skabardonis *et al.*, 2014). The alteration or adjustments of a control system in order to provide a suitable performance is called compensation.

A compensator is an additional component or circuit that is inserted into control system to compensate for a deficient performance. Compensation in control systems is necessary if a given system does not conform to set design criteria. System designers can improve transient response characteristics, such as rise time, settling time, and overshoot, as well as steady state error with help of compensators such as lead, lag, fuzzy logic, neural networks, proportional, proportional-integral, proportional – derivative and proportional-integral-derivative controllers. Compensators are used to alter the response of a control system in order to accommodate set design criteria (Bakare & Tahir, 2018).

## 2.0 MATERIALS AND METHOD:

In order to design and implement a control system the following essential generic elements are required:

- (i) Knowledge of the desired value: It is necessary to know what is required to be controlled, to what accuracy, and over what range of values. This must be expressed in the form of a performance specification. In the physical system this

information must be converted into a form suitable for the controller to understand (analogue or digital signal).

- (ii) Knowledge of the output or actual value: This must be measured by a feedback sensor, again in a form suitable for the controller to understand. In addition, the sensor must have the necessary resolution and dynamic response so that the measured value has the accuracy required from the performance specification.
- (iii) Knowledge of the controlling device: The controller must be able to accept measurements of desired and actual values and compute a control signal in a suitable form to drive an actuating element.
- (iv) Knowledge of actuating device: This unit amplifies the control signal and provides the ‘effort’ to move the output of the plant towards its desired value.
- (v) Knowledge of the plant: Most control strategies require some knowledge of the static and dynamic characteristics of the plant. These can be obtained from measurements or from the application of fundamental physical laws, or a combination of both (Bakare & Tahir, 2019).

A smart traffic light system or an intelligent traffic light system is one which is controlled by some form of intelligence (code) which is preprogrammed on the device. These systems may be fully automated (i.e., they do not require any form of human control or intervention to operate) or they could be semi-automated (i.e., they require some form of human control to function optimally. This was achieved using an Arduino Nano programmable logic controller (PLC), traffic light (LEDs), Light Dependent Resistors (LDRs), diodes and resistors. This system was designed and simulated on the Proteus 8 Professional platform with the intelligence developed on the Arduino 1.8.7 IDE. The system was designed such that the control of the traffic lights was dependent on signal time and also on the population of vehicles on each lane. Two LDRs were used per lane and were positioned at various distances from each other.

When both LDR's on a lane were parked over, their resistance increases. This resistance is fed to the Arduino Nano for interpretation and actuation of the traffic lights. When such signal is received, the Arduino Nano shut off all other lanes, allowing the most populated lane the right of way.

## 2.1 The Mathematical Model

The Proteus design Suite which is a proprietary software tool suite used primarily for electronic design automation was used as an environment for simulation and therefore the developed mathematical models were based on Proteus design suite. An n-road intersection may be considered as an n-dimensional problem in which each of the roads forming the intersection is considered as a separate entity that employs a digital n model sensor. In order, to formulate a mathematical model for typical traffic road intersections, some parameters were chosen. In order to ease the development of the model, we considered a typical n-road intersection, having left and right lanes on each road at the GRA junction in Port Harcourt, Rivers State. Therefore, the following assumptions were used work:

- (i) That each of the road forming the intersection has two lanes that are wide enough to support three separate vehicle queues.
- (ii) Vehicles are allowed to queue-up on each lane according to their intended motion direction decision, i.e.
  - A. Left decision = Left part of the lane
  - B. Right decision =right part of the lane
  - C. Straight decision =center of the lane
- (iii) Delay is not caused by service vehicles crossing the intersection in non-conflicting manner i.e., vehicles do not maneuver their way while at the intersection.
- (iv) The sensors can detect vehicles on each of the lane regardless of their speed and position i.e., vehicles are accurately counted.

Let  $\lambda_i$  denote the average arrival rate of vehicles on the  $i$ th lane measured over a considerable large time interval; Let  $\mu_i$  indicate the average departure rate of vehicles on the  $i$ th lane; let  $t$  denote a time interval. Therefore, the values of  $i$  will be a constant 4. Since 4 is the number of

roads forming the intersections. The total number of vehicles at the intersection at any time can be expressed using (Yousef *et al.*, 2010):

$$N = N_0 + \sum_{i=1}^n \lambda_i (T - t_0) - \sum_{i=1}^n \mu_i (T - t_0) \quad (1)$$

Thus,

$$N_0 = \sum_{i=1}^n (N_{0i}) \quad (2)$$

Where:

$T$  is the current/present time instant.

$N$  is the total number of vehicles at the intersection at a given time instant

$N_0$  is the total number of vehicles on roads, at the time when monitoring begins

$t_0$  is the start time / initial time

$N_{0i}$  is the initial queue length on the  $i$ th road

$\sum_{i=1}^n \lambda_i (T - t_0)$  is the total number of vehicles that have departed within the interval.

$\sum_{i=1}^n \mu_i (T - t_0)$  is the total number of vehicles that have departed within the interval.

Therefore, replacing  $T - t_0$  with  $t$ , and re-organizing (1) can give rise to (2) as follows:

$$N = \sum_{i=1}^n N_{0i} + \lambda_i T - \mu_i T \quad (3)$$

Equation (3) represents the objective function of the Sensor Based traffic light controller which has to be minimized at any instant in time. Let  $\lambda$  represent the average arrival rate at the intersection; let  $\mu$  represent the average departure rate of the intersection, (4) and (5) can be used to express  $\lambda$  and  $\mu$  in terms of their equivalents for each of the roads (Yousef *et al.*, 2010).

$$\sum_{i=1}^n \lambda_i \quad (4)$$

$$\sum_{i=1}^n \mu_i \quad (5)$$

The average waiting time on the  $i^{\text{th}}$  road can therefore be expressed as:

$$AWT_i = \frac{N_{0i}}{\lambda_i} \quad (6)$$

While, the average waiting time for the entire system is also expressed as in (Yousef *et al.*, 2010):

$$AWT = \frac{N}{\lambda} \quad (7)$$

## 2.2 Material Selection

The Arduino Nano is a small, complete, and breadboard-friendly board built around the ATmega328P microcontroller. It consists of 14 digital input/output pins (I/O pins) 0 to 13, six of which are Pulse Width Modulation pins (PWM pins). In this work, the traffic lights are connected on digital pins 2 to pin 13. These pins are used in controlling the actuation of the traffic lights. The LDR sensors used for lane population detection are connected to pins A0-A7. Eight LDR sensors are employed in this design with two planted per lane.

An LDR is an electronic component with a (variable) resistance that changes with the light intensity incident on it. In this work, the LDR sensors are connected to the ADC pins of the Arduino Nano board. This connection is done using a 10k ohms resistor. In using the LDR as the lane population detectors, an increase in the intensity of light on the LDR signifies fewer vehicles on that lane.

Diodes are devices which allow the flow of current in only one direction. That is the current only flows from the Anode to cathode. The maximum current carrying capacity for 1N4007 is 1A but it can withstand peak current of up to 30A. Thus, it is used in circuits that are designed for less than 1A. The reverse current is 5uA which is negligible. The power dissipation of this diode is 3W.

The traffic light components used in this work is selected from the component list on Proteus 8 professional platform. The traffic light consists of three coloured lamps (red, yellow and green). These lamps are connected to the digital I/O pins of the Arduino Nano controller.

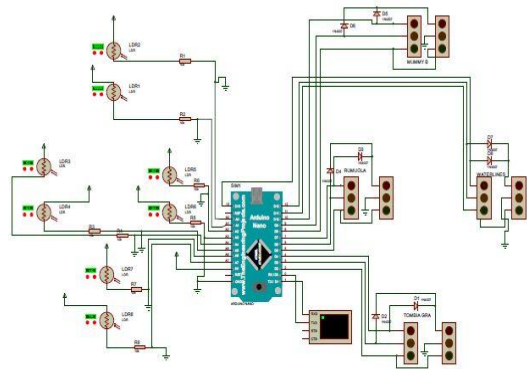

**Fig 1. Intelligent traffic light system circuit diagram**

The software controlling the intelligent traffic light system is developed in C++ language over the Arduino version 1.8.7 IDE (Integrated Development Environment). This IDE compilers can convert the C++ code (.cpp) to machine code (.hex).

The software is designed such that each lane is allocated a traffic light stand with five traffic lamps on it. These lamps are colour coded red, yellow, and green. The code is written such that a pass time of 2500 milliseconds is allocated to each lane. The lanes are passed sequentially. The LDR sensors on each lane are used in determining the population of vehicles on each lane. Considering the average length of a car to be 4.5m, these sensors are to be placed thirty-two meters apart, accommodating seven cars on a lane. When a lane is observed to be more populated than all others, the traffic light pass sequence is broken, giving preference to the most congested or populated lane.

Proteus is a circuit simulation application for virtual systems design and modelling. Proteus suite combines mixed mode spice circuit simulation, animated components and microcontroller models to carry out co-simulation of microcontroller-based design.

## 3.0 RESULTS AND DISCUSSION:

### 3.1 Results

The results obtained from the simulation of the intelligent traffic light system developed in this



work for GRA junction, Port Harcourt is presented as follows. These results were obtained on the Proteus 8.9 Professional platform. The respective junctions are named Tombia GRA, Mummy B, Rumuola and Waterlines. In simulating the system, it was assumed that the traffic light stands are positioned at the sides of each lane.

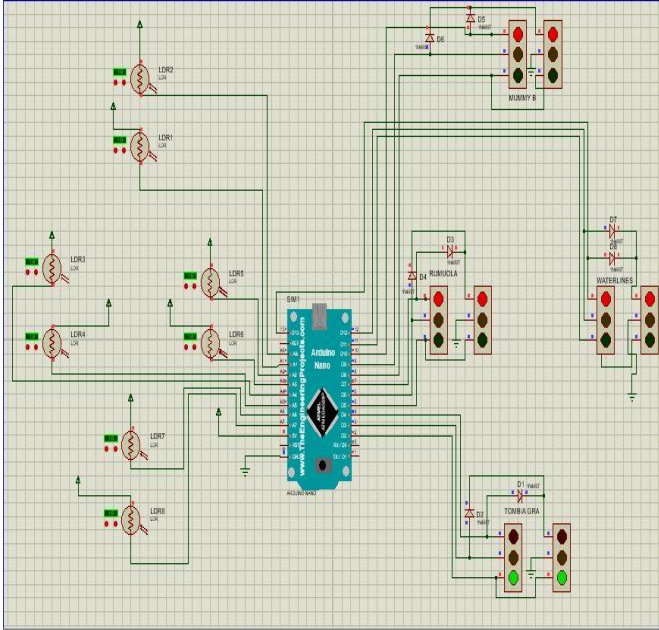

**Fig 2. Simulation showing Tombia GRA having right of way**

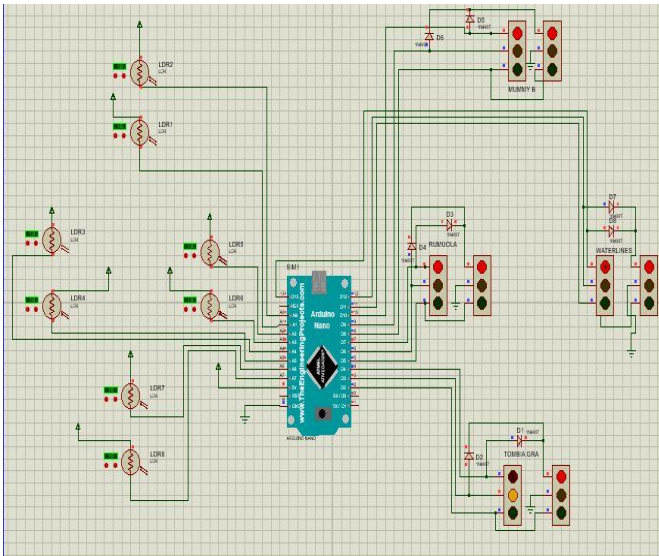

**Fig 3. Simulation showing Tombia GRA getting ready to stop**

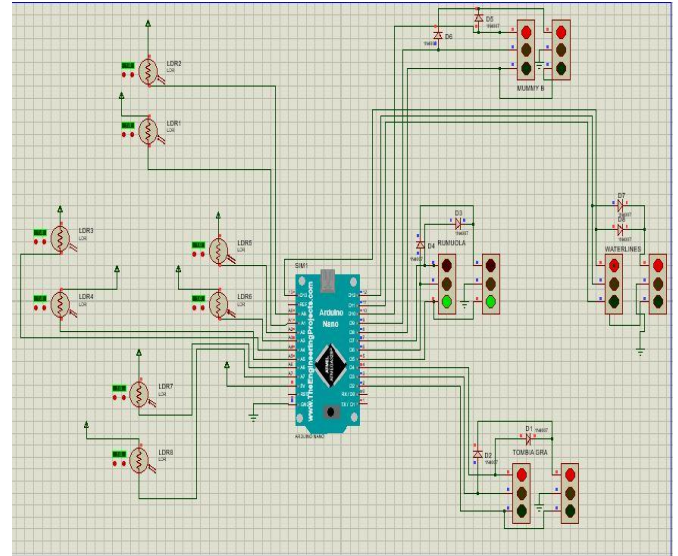

**Fig 4. Simulation showing Rumuola having right of way.**

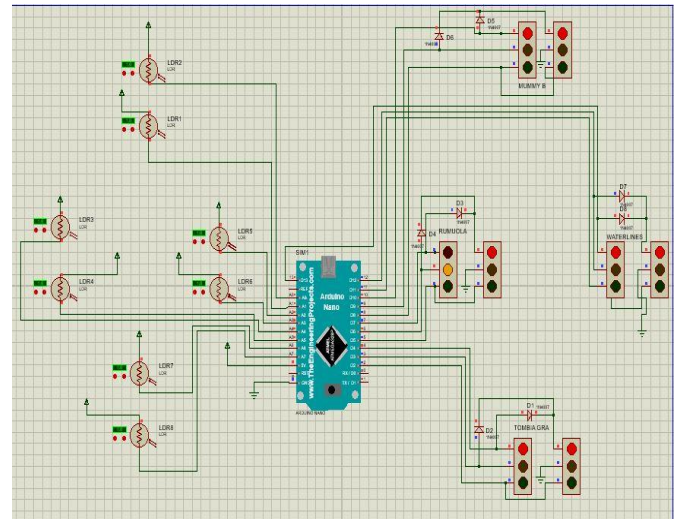

**Fig 5. Simulation showing Rumuola getting ready to stop**

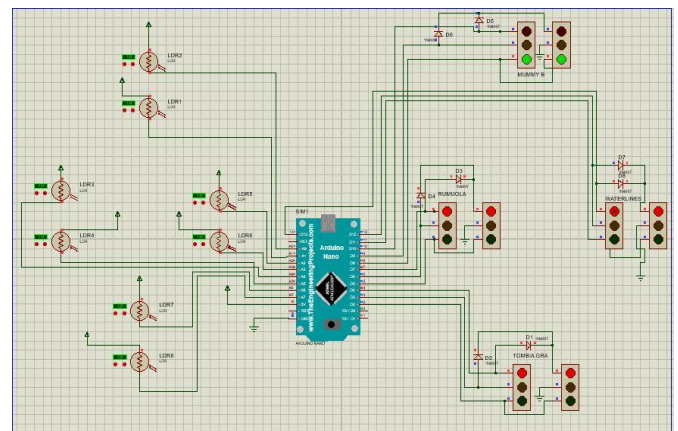

**Fig 6. Simulation showing Mummy B having right of way**





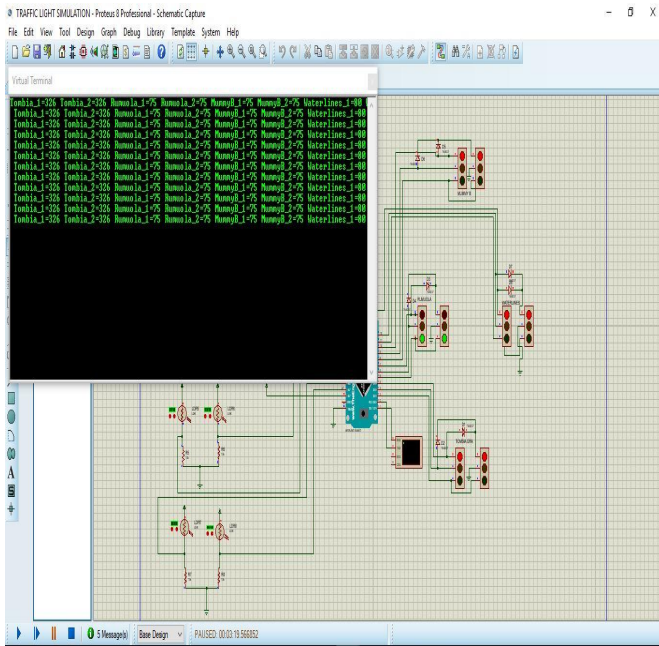

**Fig 13. Lane Population Detection giving preference to Mummy B ignoring Tombia GRA lane**

### 3.2 Discussion

From the results obtained from the intelligent traffic light system, several observations were made. Figs. 2, 3, 4, 5, 6, 7, 8 and 9 the pass sequence of operation of the intelligent traffic light can be observed. It can be seen that only one lane is allowed right of way at any particular time. This ensures safety of road users when obeyed. It can also be observed from Figs. 3, 5, 7, and 9, that the yellow lamp is switched on for a shorter time, to indicate a warning (get ready to stop) to vehicles on that lane.

In Fig. 10, the virtual terminal can be seen showing the corresponding light intensity on the LDR sensors. It can be observed that Rumuola, Mummy B and Waterlines lanes are congested as a lower light intensity of 75,75 and 80 can be observed on these lanes compared to that of Tombia which is at 326. This indicates that there is lesser number of vehicles on the Tombia axis compared to the other three thus activating preferential lane selections.

In Figs. 11, 12, and 13 it can be observed that the normal traffic light sequence shown in Figs. 2, 3, 4, 5, 6, 7, 8 and 9 is broken and preferential lane selection is activated. It can be observed that Rumuola, Mummy B and Waterlines Lanes are

preferred and given right of way while ignoring Tombia Lane which is less congested. Thus, through the use of LDR sensors for lane population detection, lane congestion is reduced.

### 3.3 Results Validation

The intelligent traffic light system designed in this research work is unique from those developed by previous researches. In the work of Goutham *et al.* (2014), an intelligent traffic light system was designed and simulated, the operation of which was based on road traffic density measurements, and cameras were used to aid the measurement of the road traffic density. The footages from these cameras were viewed in real time by operators who interpreted the traffic density from the footage and actuate the traffic lights to give preference to lanes which were more congested. From the results obtained in this work (Figs. 11-13), it is observed that lane population or road traffic density is measured, interpreted and preference (right of way) given to the most populated lanes without the aid of any human intervention.

When compared with the work of Muzhir and Khatlab (2016) who worked on an intelligent traffic light control system based on image intensity measurements which relied on image capturing in determination of lane population and allocation of right of way. Unlike this system where an algorithm was used in interpreting the image and preference given to the most congested lane(s), the intelligent traffic light system developed in this work relies on LDR which are less expensive and easier to implement.

### 4.0 CONCLUSION

In this work, an intelligent traffic light system was developed. This system was designed and simulated on the Proteus 8.9 SP3 platform. The intelligence controlling the operation of this system was developed on the Arduino 1.8 IDE and was written in C++ programming language. This system was designed using several circuit components such as the Arduino Nano, Light Dependent Resistor sensors, 10K resistors and Traffic Light Lamps all obtained from the component list on Proteus. This system



developed in this work is based on signal timing sequence and lane population detection.

Two LDR sensors are placed per lane and thirty-two meters apart from each other, accommodating seven cars on a lane. The system operates on signal timing sequence when all lanes have approximately the same population of vehicles and when the populations on all lanes do not exceed the last LDR placed in each lane. It was observed that when this sequence was in place, only one lane was passed (given the right of way) at a time thus ensuring safety of vehicles plying the road.

Lane preference is activated by the lane population sensors when the population of vehicles in a lane exceeds seven on that lane thus giving such lane or lanes right of way and ignoring the lane with less vehicles as shown in the results obtained in Figs. 11, 12 and 13. Thus, unlike the conventional traffic light systems which operate only on signal timing sequence, through the use of lane population detection, right of way is given to more congested lanes in the intelligent traffic light system developed in this work. This when implemented will greatly reduce traffic congestion in GRA junction Port Harcourt during rush hours.

## REFERENCES

- Bakare, B. I & Tahir, A. B (2018). Simulation of Direct Current (D.C) Electrical Motor Speed Control. *American Journal of Engineering Research*. 7(7), 148-156
- Bakare, B. I & Tahir, A. B (2019). Second-Order Sensitivity Technique for Optimal DC motor Speed Control. *European Journal of Advances in Engineering and Technology*, 6(7), 20-32
- Goutham, R. N., Roza, J. S., & Santhosh, M. (2014). Intelligent Traffic Signal Control System *International Journal of Advanced Research in Electrical, Electronics and Instrumentation Engineering*, 3(4), 221-230.
- Mahmood, M. N., Othman, C. P., & Arash, M. R. (2009). Optimization of Traffic Signal Coordination System on Congestion: A Case Study. *WSEAS Transaction on Advance in Engineering Education*. 6(7). 203-212.
- Muzhir, S. A., & Khattab, A. (2016). Intelligent Traffic Light Control System Based Image Intensity Measurement. Anbar University College of Computer Science Iraq. 1-7
- Muzy, A., Innocenti, E., Aiello, A., Santucci, J. F., Wainer. G. (2015). Specification of Discrete Event Models for Fire Spreading. *SIMULATION*, 81(2). 1-15.
- Scholz, T. (2008). Light Sources for Signal Systems. *Lighthouse*. 1<sup>st</sup> Edition. 1-39.
- Skabardonis, A., Bertini, R. Gallagher, B. (2014). Development and Application of Control Strategies for Signalized Intersections in Coordinated Systems. Transportation Research Record No. 1634. Transportation Research Board, National Research Council, Washington, D.C. 110-117
- Urbanik, T., Tanaka, A., Lozner, B., & Bullock, D (2015). Signal Timing Manual. *National Cooperative Highway Research Program Report*. 6(812). 4-7.